



# Receiver Microphonics Caused by Heater-Cathode Capacitance Variations

One of the sources of microphonics in conventional superheterodyne receivers is small variations in the heater-cathode capacitance of the oscillator tube which are produced by vibration and which occur at an audio frequency. When the vibration is caused by the loudspeaker, acoustic feedback may take place and an objectionable howl will result. In an FM receiver, microphonics can be readily detected as frequency modulation of the oscillator. In an AM system, microphonics are evident when the receiver is slightly off tune. Under this condition, the center frequency is located on the side of the intermediate-frequency response curve and frequency variations cause changes in amplitude. In the 500-to-1600-kilocycle standard broadcast band, microphonics caused by variations of the heater-cathode capacitance are negligible and, therefore, ordinarily require no special design precautions.

This Note describes design and construction precautions for minimizing microphonics by eliminating the effects of heater-cathode capacitance variations in an oscillator tube of a receiver operating in the FM, television, or other short-wave bands.

The heater-cathode capacitance for tube types 6SB7-Y and 6BE6 is approximately three micromicrofarads. If the oscillator of an FM receiver operating at 100 megacycles has a total tank capacitance of 25 micromicrofarads, a change as small as 0.00375 micromicrofarads causes a frequency deviation of 7500 cycles. If this deviation is recurring, it corresponds to a five-per cent modulation of a 150,000-cycle FM bandwidth. If the deviation takes place at an audio-frequency rate, such a capacitance change, although small, is of sufficient magnitude to cause a microphonic howl in a high-frequency receiver.

A typical 100-megacycle converter circuit employing a Hartley-type oscillator is shown in Fig. 1. In a pentagrid converter such as the 6SB7-Y or the 6BE6, grid No.2 (screen) functions as the oscillator anode and is at rf ground. The cathode is connected to a tap on the



tank coil and the heater-cathode capacitance is, therefore, across part of the tank circuit. If there is movement of the heater in the cathode sleeve at an audio frequency due to vibration, the heater-cathode capacitance will vary at an audio frequency and will in turn modulate the frequency of the oscillator. Microphonics can be minimized in this circuit if an arrangement is utilized which limits the effect of heater-cathode capacitance variations on the oscillator. This effect can be eliminated almost entirely by tying one heater lead to the cathode. The only other circuit change required is the insertion of an rf choke in the second heater lead to prevent the heater from loading the oscillator. See Fig. 2. A ground return for the heater is provided through the cathode tap on the oscillator.

Suggestions and considerations for utilizing this method in various types of receivers follow.

- a. In single-band ac FM receivers, use circuit of Fig. 2. To prevent the heater from loading the oscillator, the inductance of  $L_1$  should be large compared with the inductance of the tapped section of the oscillator coil. In the FM band, a value of one microhenry for  $L_1$  is adequate.
- b. In short-wave multi-band (AM/FM) ac receivers, use circuit of Fig. 2. The value of  $L_1$  should be sufficient to prevent the heater from loading the oscillator at the lowest frequency band.
- c. In ac/dc receivers in which the oscillator or converter tube is at the ground end of the heater string, use circuit of Fig. 2. To prevent the heater from loading the oscillator, the inductance of  $L_1$  should be large compared with the inductance of the tapped section of the oscillator coil.
- d. In ac/dc receivers in which the oscillator or converter tube is not at the ground end of the heater string, use circuit of Fig. 3. Representative values for an ac/dc receiver operating in the FM band are:

$$\begin{aligned} L_1, L_2 &= 1 \text{ microhenry} \\ C_1 &= 68 \text{ micromicrofarads} \end{aligned}$$

In this circuit, the value of  $C_1$  is selected so that the heater is effectively short-circuited to the cathode throughout the FM band.

Because the oscillator coil in the AM broadcast band is often made of very fine wire not capable of carrying heater current, it may be desirable to use a switching arrangement which ties the heater to cathode when the receiver is operating in the FM band but which disconnects the heater and cathode in the AM band. A typical switching arrangement is given in Fig. 4.

Some precautions to observe in the design and construction of these circuits follow.

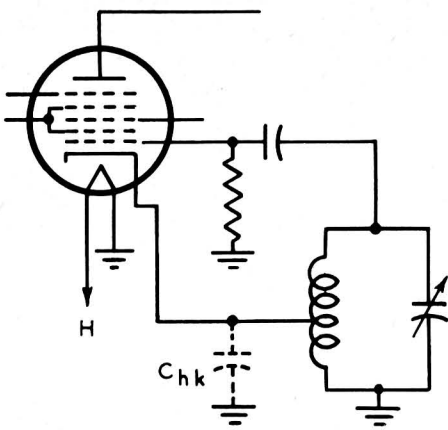

Fig. 1

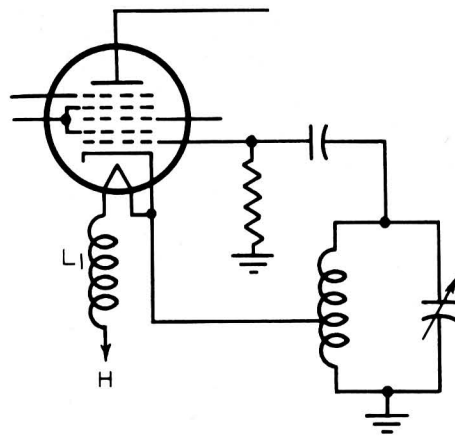

Fig. 2

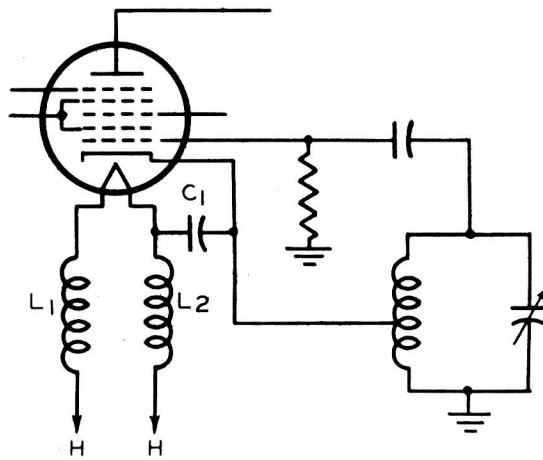

Fig. 3

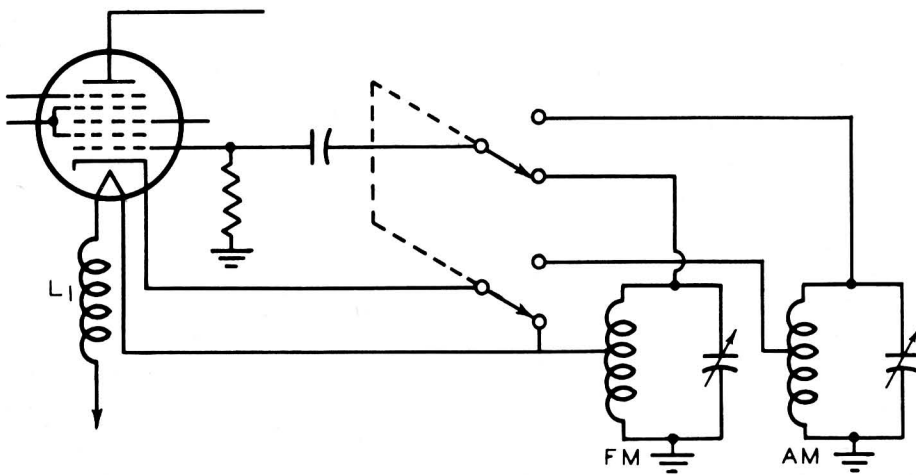

Fig. 4



1. When the circuit of either Fig. 2 or Fig. 4 is used, the choke  $L_1$  and the high-frequency oscillator coil have to carry heater current and should be designed accordingly.

2. The resistance of the chokes and coils in series with the heater of the tube should be kept low in order to avoid operating the tube at reduced heater voltage. If the heaters are in parallel, it is generally not difficult to keep the voltage drop across the choke below 0.05 volts. If the heaters are in series, the voltage drop is not important but the heat dissipation in the choke and coil windings should be kept to a safe value.

3. The coils employed for one band should not produce resonant effects in other bands of the receiver.

4. Precautions against microphonics caused by variations in heater-cathode capacitance should be incorporated in the early stages of design. Later adoption may result in tracking difficulties or loss of sensitivity.

Many of the devices and arrangements shown or described herein use inventions of patents owned by RCA or others. Information contained herein is furnished without assuming any responsibility for its use.